

LOT LINE EXHIBIT

LEGAL DESCRIPTION:

LINE BETWEEN LOT 10 AND LOT 9,
BLOCK 2, OAK PARKE ESTATES 2ND
ADDITION

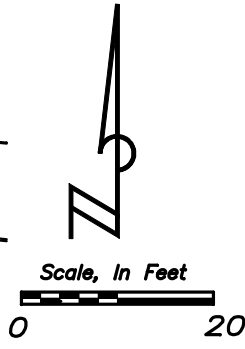
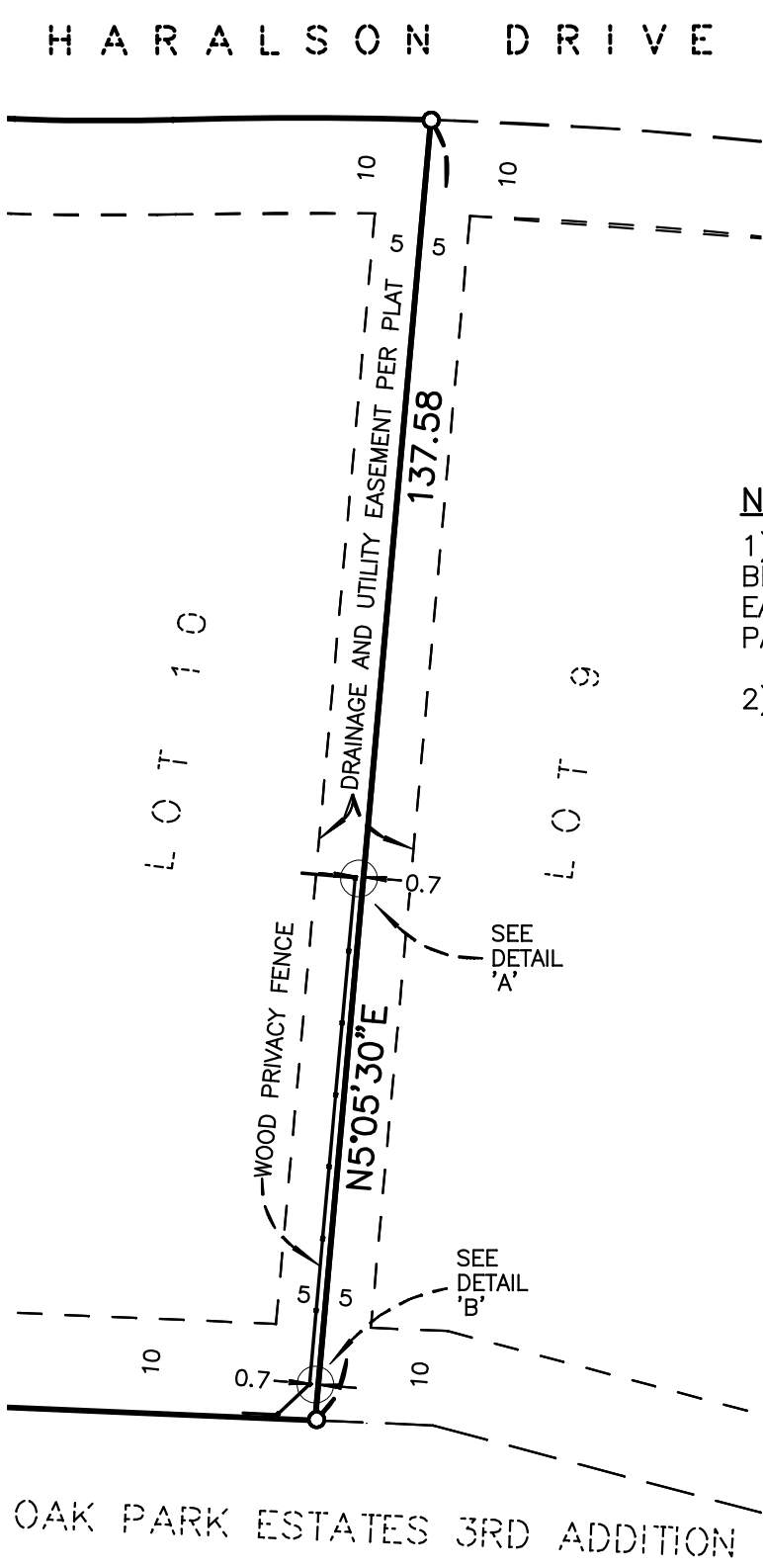

LEGEND:

○ SET 1/2" REBAR
W/CAP #44109

NOTES:

- 1) THIS SURVEY WAS PERFORMED WITHOUT THE BENEFIT OF A TITLE INSURANCE COMMITMENT. EASEMENTS SHOWN ARE PER PLAT OF OAK PARKE ESTATES 2ND ADDITION.
- 2) BEARING BASIS IS ASSUMED.

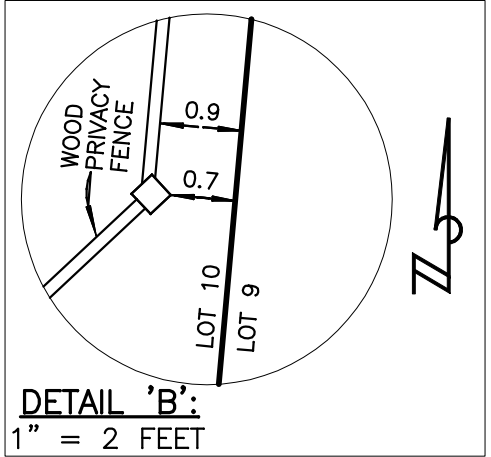
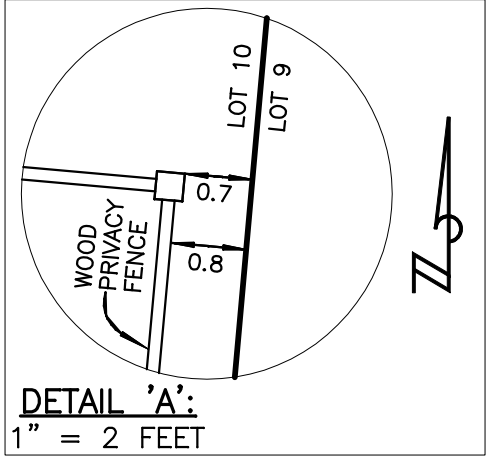

CERTIFICATION :

I hereby certify that this survey, plan, or report was prepared by me or under my direct supervision and that I am a duly Licensed Land Surveyor under the laws of the state of Minnesota.

PREPARED FOR:

SIGNED : *Travis W. Van Neste*

Travis W. Van Neste, Minnesota Professional Surveyor #44109
Michigan Professional Surveyor #46695

JOB #	ISSUED:	
DRAWN BY: TWVN	REV:	
SCALE: 1" = 20 FEET		

VAN NESTE SURVEYING
PROFESSIONAL SURVEYING SERVICES
85 WILDHURST ROAD EXCELSIOR, MN 55331
PHONE (952) 686-3055 TOLL-FREE FAX (866) 473-0120
WWW.VANNESTESURVEYING.COM

